

PARTS & SERVICE DEPARTMENT

300 Maddox Simpson Pkwy
Lebanon, Tennessee 37090
615-889-8900 Fax: 615-882-2963
www.Lochinvar.com

Date: July 27, 2011

Bulletin Number: 2011-06 T

TO: Manufacturers' Representatives, District Sales Managers, Regional Managers, Technical & Customer Service Personnel, Service Agents, Sales & Marketing Personnel

SUBJECT: Sync Boiler System Sensor

Recent customer inquiries have indicated that there may be some confusion as to why a system sensor is required when installing SYNC boilers. It was discovered that customers that have been reporting control and operational problems with their SYNC units, have not been installing or using the system sensor that was supplied with the boiler. After the system sensor was connected the control and operational issues were resolved. This bulletin is provided to explain why a system sensor is needed and where to locate the system sensor for proper SYNC operation.

SYNC Boiler System Sensor

The SYNC boiler is a unique boiler design that incorporates two combustion systems and two heat exchangers under one control system to deliver a large heating capacity with a rapid response time. For proper operation of the SYNC a system sensor must be installed. Therefore, a system sensor is provided as standard equipment with every unit.

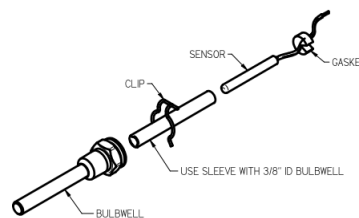

What systems need a system sensor?

It is the recommendation of Lochinvar that all SYNC boilers be installed with a system sensor. Each individual stand-alone boiler should have a system sensor installed and wired directly to itself. When multiple SYNC boilers are operating in cascade mode it is only necessary that Leader boiler be wired to the system sensor.

Where do I need to install the system sensor?

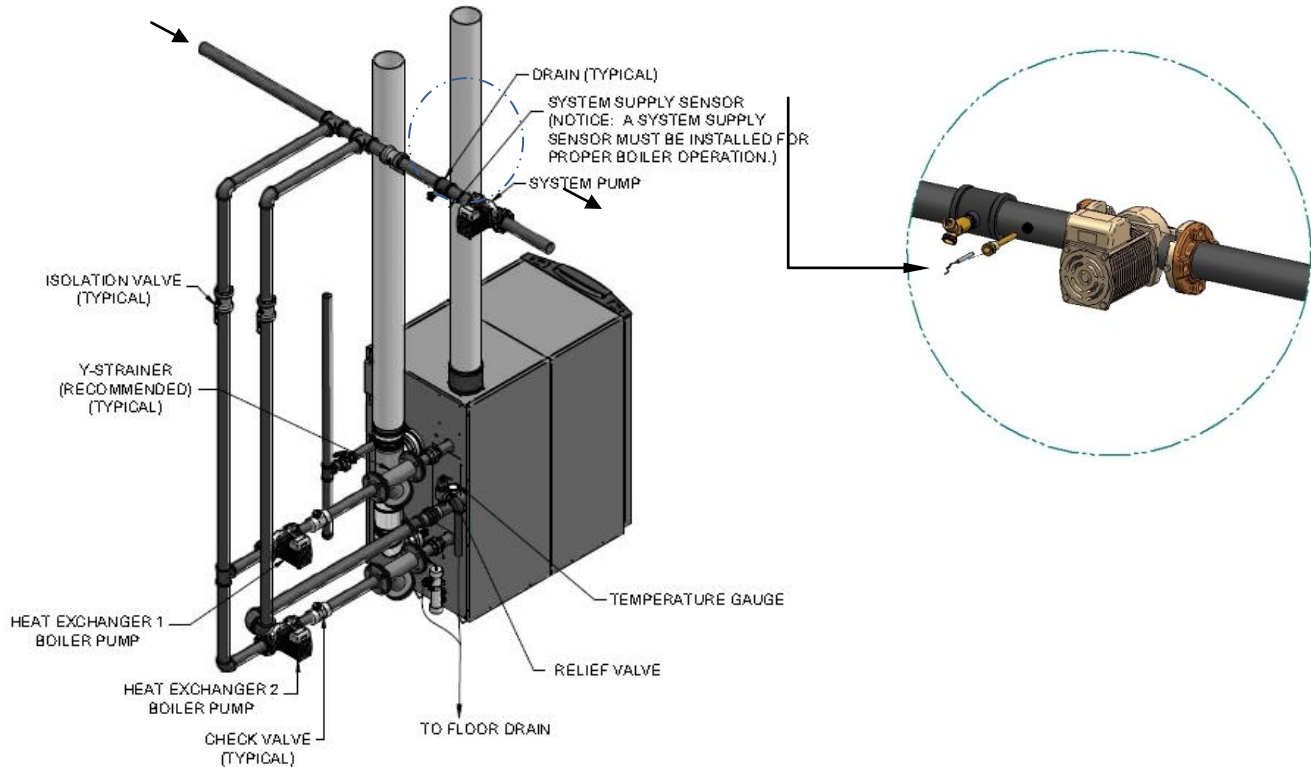

Why is the system sensor so important?

The system sensor is used to determine the amount of energy that is needed by the heating system at the desired set point (heat demand). Because this heat demand is constantly changing it requires real time feedback to the SYNC boiler to determine firing and modulation rates, as well as minimum on and off times. The goal of the SYNC boiler is to drive the system temperature to the set point as quickly as possible to meet the heat demand, and then modulate to the lowest and most efficient firing rate needed to maintain the heating load. A properly installed system sensor will provide a stable point of reference for the SYNC boiler's heat demand calculations.

What can I expect if the system sensor is not installed?

Erratic behavior will result. Without the system sensor installed the SYNC uses the individual outlet and inlet sensors on the dual heat exchangers to make heat demand calculations. While this provides fail safe action, it does not provide smooth operation. The reason for this is due to the rapid change of the outlet temperature of the heat exchangers as compared to the system temperature. When the outlet temperature rises too quickly it causes the heat demand to be recalculated which in turn causes the SYNC boiler to turn the combustion systems off. After the combustion system is turned off the heat exchanger is filled with relatively cool water from the system return, which then causes the combustion system to be turned back on immediately after just being turned off. This erratic behavior will vary from system to system depending on system mass and differences in BMS control scheme.

Do SYNC boilers connected to a building management system (BMS) need a system sensor?

Yes, under most conditions. When connected to a BMS the SYNC boiler will still require the system sensor to properly calculate the heat demand. The SYNC boiler can be connected to a BMS by either a 0-10VDC signal or through ModBus communications and can be configured to operate based on set point or modulation percent.

When connected via 0-10 VDC and configured to operate based on set point the system sensor must always be wired to the unit to properly calculate the heat demand. When connected via 0-10VDC and configured to operate based on modulation percent the system sensor is not required because the boiler is not using it to calculate the heat demand. If the 0-10VDC signal is lost the boiler will assume the input to be 0 and will remain off except for freeze protection. Therefore, even with a loss of communication the system sensor will not be utilized when in modulation percentage mode.

When connected via ModBus communication the system sensor must be installed to maintain operation should ModBus communications be lost. If the Modbus communications timer expires the boiler is designed to revert back to internal programming to maintain heating capacity and will utilize the locally connected system sensor.

The SYNC boiler has six demand configurations in the set up menus. Please refer to the summary table T1 for the application of the system sensor.

Table : T1

Demand Configuration	External Control	Demand Type	Enable Signal	Controlling Sensor	System Sensor
1	None	Set Point	Thermostat Based	System	Yes
2	0-10 VDC	Modulation	Thermostat Based	None	No
2		Set Point	Thermostat Based	System	Yes
3		Modulation	Voltage Based	None	No
3		Set Point	Voltage Based	System	Yes
4		ModBus	Set Point	Thermostat Based	System
5	Modulation		Thermostat Based	None	Yes
5	Set Point		Thermostat Based	System	Yes
6	Modulation		Voltage Based	None	Yes
6	Set Point		Voltage Based	System	Yes

We hope this has helped clear up any confusion concerning the system sensor when operating SYNC boilers. Should you have any other questions please feel free to contact Technical Service at 1-800-722-2101.