

# October's Correct Diagnosis



## Hydronic Heating Sleuth's Challenge

### Answer

1. Undersized Boiler Loop Piping.
2. Improper Aquastat Connection.
3. Improper Ground to Boiler.

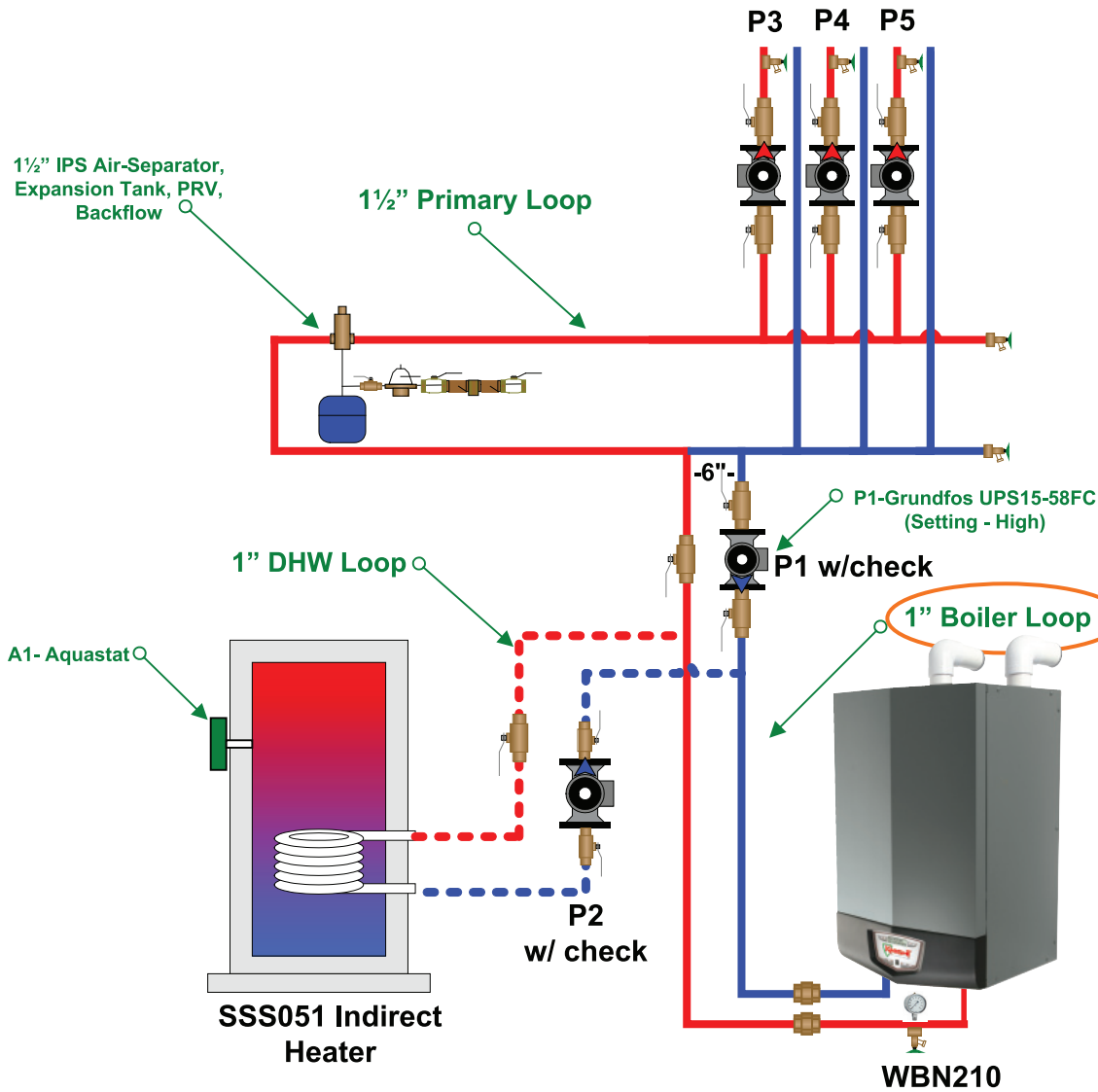

Boiler loop increased to 1" from 3/4" to help move the Btu's out to the system and to the Indirect water heater.

Aquastat properly connected to DHW Thermostat

Ground circuit complete

