



Lochinvar®

HIGH EFFICIENCY BOILERS & WATER HEATERS

**STAINLESS STEEL
SOLAR WATER HEATER**

Submittal Sheet

SET-Sub-02

STAINLESS STEEL SOLAR INDIRECT WATER HEATER WITH ELECTRIC BACK-UP

Job Name: _____ Model No. _____

Location: _____ Gal. Capacity: _____

Engineer: _____ Equipment Tag(s): _____

Agent/Wholesaler: _____

Contractor: _____

NOTES:

Model Number	Capacity (Gallons)	A	B	C	D	E	F	Domestic Water Conn.	Coil Connection Size	Shipping Weight (lbs.)
SET065	67	60"	24"	52-1/4"	28"	9-1/4"	3-1/4"	1-1/2"	1"	149
SET080	81	69-1/2"	24"	61-3/4"	28"	9-1/4"	3-1/4"	1-1/2"	1"	179
SET119	113	68-1/4"	28"	60-1/4"	31-3/4"	9-1/4"	3-1/4"	1-1/2"	1"	215

Model Number	Heat Source Water Volume (Gallons)	Standby Loss (°F/Hr)	Electric Continuous Delivery (GPH)	Electric 1st Hour Delivery (Gallons)
SET065	1.9	0.5	24	54
SET080	2.1	0.5	24	57
SET119	3.2	0.5	24	75

Standard Features

- Fully Welded Construction
- 100% Stainless Steel Construction
- Built in U.S.A. at Lochinvar World Headquarters
- 316L Passivated Stainless Steel Tank
- 316L Stainless Steel Heating Coil
- 4500W Stainless Steel Heating Element
- 1" Boiler Supply & Return Connections
- 1" Solar Heat Source Supply & Return Connections
- 1-1/2" Domestic Water Connections
- Non-HCFC High Density Foam Insulation
- Temperature and Pressure Relief Valve (Shipped Loose)
- Factory Supplied Tank Sensor
- See warranty for details:
All models standard with a five (5) year limited warranty against tank failure
One (1) year warranty on parts

Optional Equipment

Aqua Stat

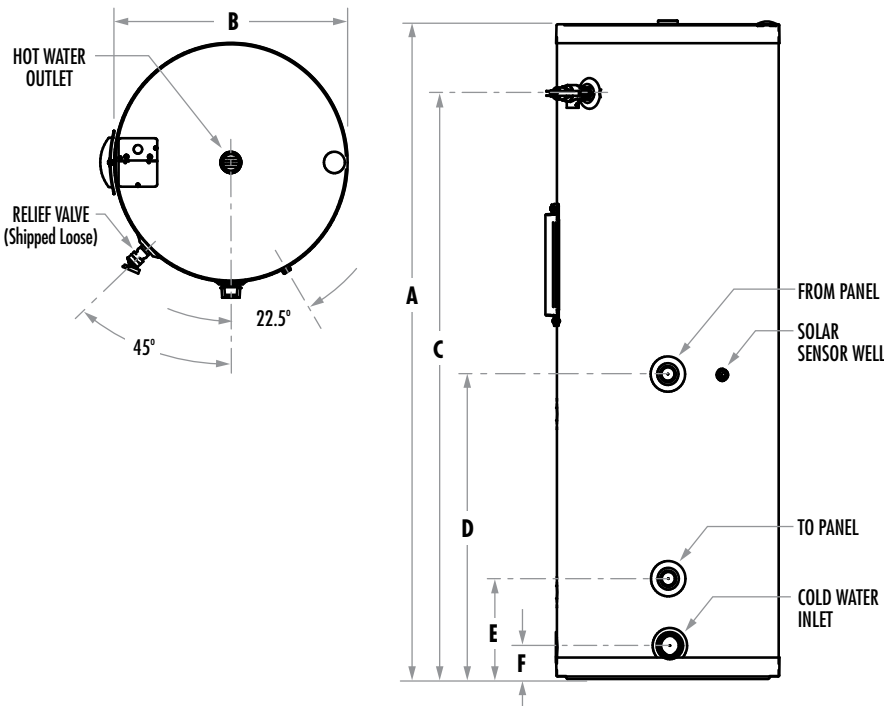

Lochinvar®
HIGH EFFICIENCY BOILERS & WATER HEATERS

Lochinvar, LLC
300 Maddox Simpson Parkway
Lebanon, Tennessee 37090
P: 615.889.8900 / F: 615.547.1000

Lochinvar.com

