

Case in Point



Lochinvar® Cuts Heating Costs by Nearly 50 Percent At Northern Indiana Center for History

The Northern Indiana Center for History, located in South Bend, Indiana, is a museum comprising two historic houses, “Copshaholm” and the “Worker’s Home”; three galleries that feature changing exhibits; galleries that explore the history of the St. Joseph River Valley, the University of Notre Dame, and the All-American Girls Professional Baseball League; as well as a children’s museum.

Built in 1896, Copshaholm is the 38-room mansion of 20th century industrialist and area philanthropist J.D. Oliver. The 12,000 square-foot building and its adjacent carriage house were

constructed of native Indiana fieldstone, which was cut on-site by European masons. One of the first homes in South Bend to have electricity, the Oliver Mansion features oak, cherry and mahogany woodwork, as well as leaded glass windows and 14 fireplaces. Surrounding the home are two-and-a-half acres of landscaped gardens, including a garden tea house, formal Italianate garden, rose garden, pergola, tennis lawn, and fountain. The home and its gardens are listed on the National Register of Historic Places and the mansion is registered as an American Treasure.

PROJECT:

NORTHERN INDIANA CENTER FOR HISTORY

LOCATION:

SOUTH BEND, IN

LOCHINVAR PRODUCTS INSTALLED:

3 - KNIGHT BOILERS (KBN500)

DESIGNER/CONTRACTOR:

Edward J. White, Inc.

EDWARD J. WHITE, INC
1011 S. MICHIGAN STREET
SOUTH BEND, IN 46601

A NEED FOR CHANGE

Edward J. White, Inc, a full-service plumbing, heating and air conditioning contractor that has served northern Indiana and southern Michigan since 1925, has serviced the estate for decades. Originally, the building's heating system was a coal-fired gravity hot water system, so it had no circulation pump and used larger piping than systems built today. The pumps were later added when the system was converted to a forced hot water system many years ago.

Until recently, the building was heated by 1920's vintage steel tube boilers. Paul White, CEO of the family-owned company, estimates that Edward J. White, Inc converted the original boilers from oil to gas approximately 30 years ago.

Two years ago, Tom Rapach, director of facilities and grounds, discovered that the



Edward J. White employees

Center had a tube leak in one of the boilers and contacted Edward J. White, Inc. Paul and his team recommended replacing the boilers rather than repairing them since future tube failures were imminent given the age of the equipment. Replacing the boilers would reduce the amount of energy used to heat the Center and lower the operating costs. Also, the high heat level and inconsistency in room temperature did not meet museum standards for the preservation of the mansion and the museum's collection.

READY FOR THE CHALLENGE

Paul and his team believed the lack of outdoor temperature reset control created too much heat for the museum in mild weather. The system had three large zone pumps and fluctuating flow rates. In addition, bringing the combustion air and venting up to today's code requirements would be difficult because of the building's age and the boiler location.

When considering what type of boiler would best meet the needs of the Center, they determined that it should be a high-efficiency model with PVC direct-vent design and an outdoor air reset control. The team also wanted 500 MBH boilers with simple sequencing.

Since Paul was familiar with Lochinvar's KNIGHT® Heating Boiler from previous installations, he knew it could offer all of these features at a reasonable price. The project's calculated design load was 1500 MBH, so he selected three KBN500 models to meet demand while minimizing the up-front costs.

Removing the old boilers was a rather challenging process because they sat in individual pits in the mechanical room. Paul and his team had to extract the boilers from these pits and then fill in the holes with concrete, which took quite a bit of time.





However, once this removal process was complete, the installation of the new boilers went smoothly and quickly due to the KNIGHT's lightweight design, small footprint and ease of set-up through the KNIGHT's exclusive SMART SYSTEM™ control.

GREAT SUCCESS

Since the installation, Tom and the other directors have been very impressed with the new KNIGHT Heating Boilers and, specifically, the cost-savings they have seen on their utility bills. During the 2005-2006 heating season, the total cost of heating the center was \$82,273.

The amount spent on energy bills throughout the 2006-2007 heating season dropped to \$43,985, which is a 46 percent difference. Based on these numbers, payback for the new system is expected to be realized in less than two years.



RESULTS AT A GLANCE...

INVESTMENT:

\$82,273 EQUIPMENT AND LABOR

FUEL SAVINGS:

46% MINIMUM SAVINGS
\$43,985 FIRST YEAR

PAYBACK:

LESS THAN 2 YEARS

BENEFITS:

IMPROVED OPERATION, STABILITY

INCREASED EFFICIENCY,
COST SAVINGS

CONSISTENT, COMFORTABLE TEMPERATURES

DESIGNER/CONTRACTOR:

EDWARD J. WHITE, INC
1011 S. MICHIGAN STREET
SOUTH BEND, IN 46601

More information on the Northern Indiana Center for History can be found at www.centerforhistory.org. Additional information on the KNIGHT Heating Boiler and other high-efficiency products from Lochinvar is available at www.lochinvar.com.

Case in Point

KNIGHT® XL BOILER DIMENSIONS AND SPECIFICATIONS

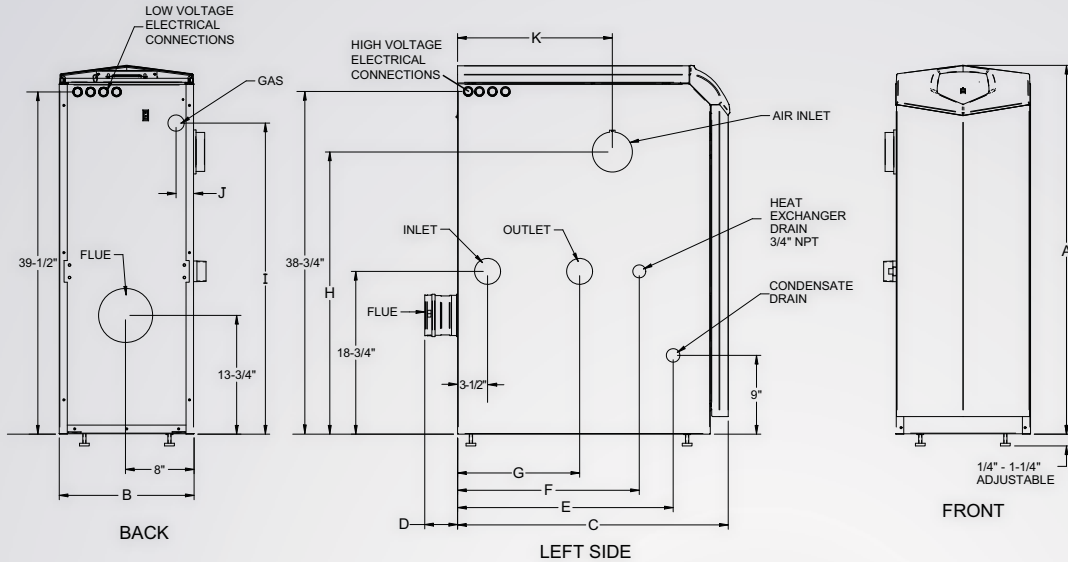

Model Number Guide			
KB	N	700	M13
Model	Natural Gas	Btu/hr Input	Firing Controls

Knight XL Boiler,
Natural Gas,
700,000 Btu/hr input,
M13 firing controls

KNIGHT XL HEATING BOILER

Model Number	Input		Thermal Efficiency	Output MBH	Net I=B=R MBH
	Min MBH	Max MBH			
KBN399	80	399	93.3%	372	324
KBN500	100	500	93.3%	467	406
KBN600	120	600	94.6%	567	493
KBN700	140	700	94.3%	660	574
KBN800	160	800	94.0%	752	654

DIMENSIONS AND SPECIFICATIONS

A	B	C	D	E	F	G	H	I	J	K	Gas				Shipping Wt. (lbs.)
											Water Conn.	Air Inlet	Vent Size	Shipping Wt. (lbs.)	
42-1/2"	15-1/2"	27"	3-3/4"	21"	20-3/4"	14"	34"	34"	2"	18-3/4"	1"	1-1/2"	4"	4"	285
42-1/2"	15-1/2"	31-1/4"	3-3/4"	21"	25"	14"	35"	35"	2"	22"	1"	1-1/2"	4"	4"	305
42-1/2"	15-1/2"	36-1/4"	3-3/4"	21"	25"	14"	36"	32-3/4"	5-1/2"	19-1/2"	1"	2"	4"	4"	355
42-1/2"	15-1/2"	40-1/4"	3"	23"	29"	17"	36"	32-3/4"	3-1/4"	23-1/2"	1"	2"	4"	6"	395
42-1/2"	15-1/2"	45-1/4"	3"	23"	33-1/4"	17"	36"	32-3/4"	3-1/4"	27-3/4"	1"	2"	4"	6"	440

Notes: Change 'N' to 'L' for L.P. Gas Model. No deration on L.P. models. Performance data based on manufacturer test results. 120 VAC / 15 AMP circuit required. All dimensions shown in inches.

STANDARD FEATURES

- Up to 94.6% Thermal Efficiency
- Modulating Burner with 5:1 Turndown
 - Direct-Spark Ignition
 - Low NOx Operation
 - Sealed Combustion
 - Low Gas Pressure Operation
- Vertical & Horizontal Direct-Vent
 - PVC, CPVC or AL29-4C Venting up to 100 ft.
 - Factory Supplied Sidewall Vent Termination
- ASME Stainless Steel Heat Exchanger
 - ASME Certified, "H" Stamped
 - All welded construction, no gaskets
 - Highly efficient, condensing design
- On/Off Switch
- Adjustable High Limit w/ Manual Reset
- Flow Switch
- Low Air Pressure Switch
- 50 psi ASME Relief Valve
- Temperature & Pressure Gauge
- Adjustable Leveling Legs
- Condensate Trap
- Zero Clearances to Combustible Material
- 10 Year Limited Warranty (See Warranty for Details)

SMART SYSTEM FEATURES

- SMART SYSTEM Digital Operating Control
 - 2 line, 16 Character Display
 - Dual Level Password Security
 - Domestic Hot Water Prioritization
 - Built in Cascading Sequencer for up to 8 Boilers
 - Building Management System Integration with 0-10 VDC Input
 - Outdoor Reset Control with Outdoor Air Sensor
 - Low Water Flow Safety Control & Indication
 - Inlet & Outlet Temperature Readout
 - Freeze Protection
 - Service Reminder
 - Time Clock
- Data Logging
 - Hours Running, Space Heating
 - Hours Running, Domestic Hot Water
 - Ignition Attempts
 - Last 10 Lockouts
- Programmable System Efficiency Optimizers
 - Night Setback
 - Anti-Cycling
 - Outdoor Air Reset Curve
 - Ramp Delay
 - Boost Temperature & Time
- Three Pump Control
 - System Pump
 - Boiler Pump
 - Domestic Hot Water Pump
- High Voltage Terminal Strip
 - 120 VAC / 50-60 Hertz / 1 Phase Power Supply
 - Three sets of Pump Contacts with Pump Relays

- Low Voltage Terminal Strip
 - 24 VAC Auxiliary Device Relay
 - Auxiliary Proving Switch Contacts
 - Flow Switch Contacts
 - Alarm on Any Failure Contacts
 - Runtime Contacts
 - DHW Thermostat Contacts
 - Room Thermostat Contacts
 - System Sensor Contacts
 - DHW Tank Sensor Contacts
 - Outdoor Air Sensor Contacts
 - Cascade Contacts
 - 0-10 VDC BMS External Control Contacts

OPTIONAL EQUIPMENT

- Alarm Bell on Any Failure
- Condensate Neutralization Kit
- High & Low Gas Pressure Switches w/ Manual Reset (KB500-KB800)
- Low Water Cutoff w/Manual Reset & Test
- SMART SYSTEM PC & Pocket PC Software
- Stainless Steel Vent Kits
- Multi-Stack Frame

FIRING CODES

- M9 Standard Construction
- M7 California Code
- M13 CSD1 / FM / GE Gap (KB500-KB800)

